

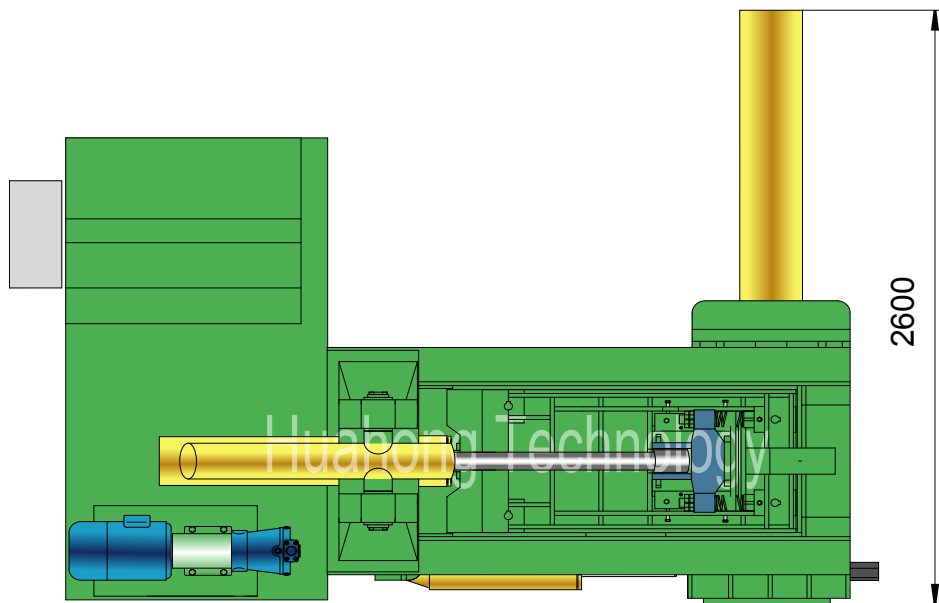

# YE81T-63A

## Plan View

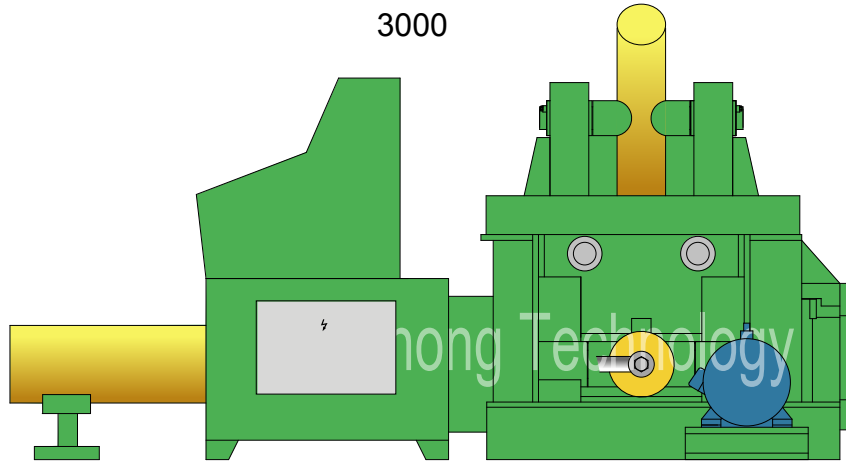

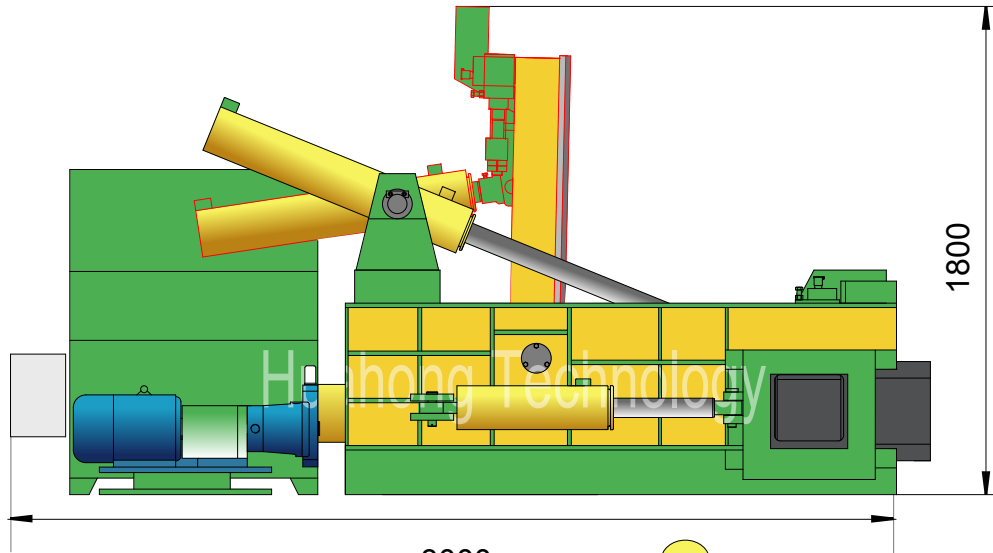

# YE81T-63A

## Technical parameters

### "Push-out" Type Metal Baler

Model: YE81T-63A

### Power System (Motor)

Type: Y160M-4  
 Rated Power: 11 kW  
 Rated Speed: 1460 rpm  
 Power Spec: 3PH, 50 / 60Hz

### System Parameters

Lid Cyl. Force: 24 Ton  
 Side Pressure Cyl. Force: 50 Ton  
 Main Pressure Cyl. Force: 63 Ton  
 Small Door Cyl. Force: 24 Ton  
 Hydraulic System Pressure: 25 MPa  
 Idle Cycle Time: Approx. 90 Sec

### Hydraulic System (Pump)

Type: 40YCY14-1B  
 Rated Displacement: 40 ml/r  
 Max Operating Pressure: 31.5 MPa

### Operation System (Optional)

Option 1: Manual Valve Operation  
 Option 2: PLC Operation

### Standard Configuration

#45 Steel Liners 18mm, Wholly Heat Treated;  
 NOK (JAPAN) Seal Packings for Cylinders;  
 Cooler / Heater; Magnetic Oil Filter.

### Optional Configuration

Cutting Blades & Teeth (2 sides); Loading Hopper;  
 Mn65 Steel Liners for High Pressure Chamber;  
 Diesel / Diesel Generator for Power.

### General Description

Main Machine Size (L×W×H): 3000×2600×1800 mm  
 Press Box Size (L×W×H): 1000×600×500 mm  
 Bale Size (W×H): 200×200 mm  
 Bale Weight (Steel): 15-30 kg  
 Production Rate (Steel): 0.4-0.8 tons/hr  
 Shipping Weight: Approx. 4.5 tons  
 Loading (Standard Containers): 1×20'GP

### Hydraulic Oil Brand

Oil Tank Volume: 300 ltr

ISO VG	China	U.S.		Britain	France
	GB11118.1	CALTEX CO.	MOBIL	SHELL	ELF CO.
HM 46	46 #	Rando HD46	D.T.E46	Tellus 46	Elfolna 46
HM 68	68 #	Rando HD68	D.T.E68	Tellus 68	Elfolna 68

Above information are indicative not engaging. Rights reserved for change if necessary.