

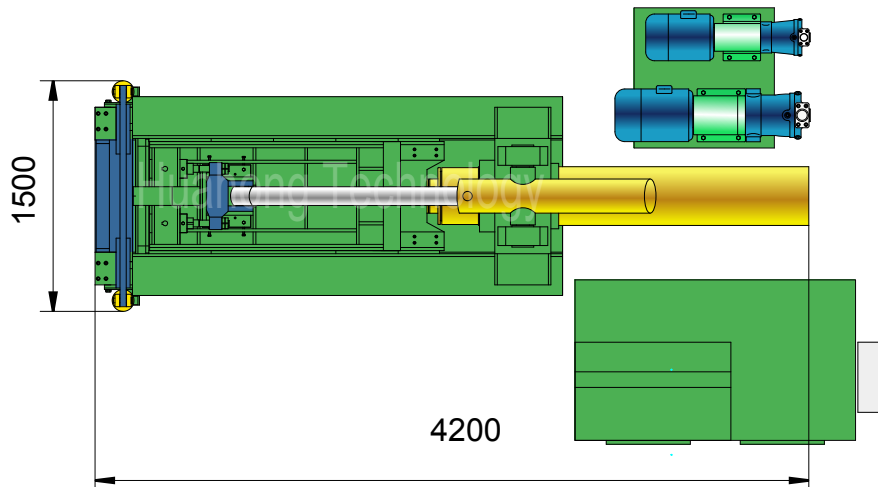

Y81Q-200

Plan View

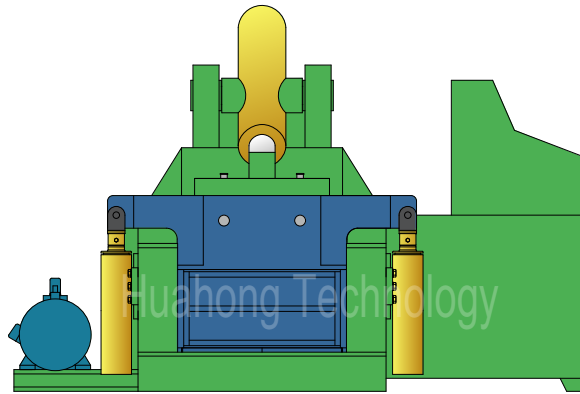

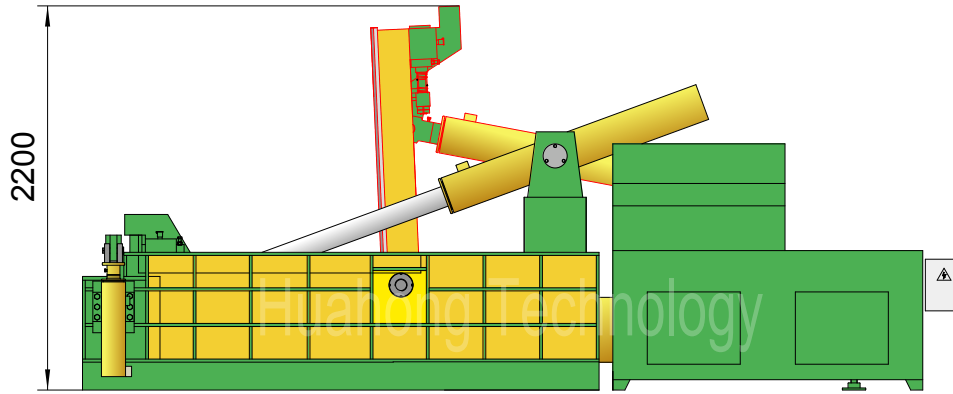

Y81Q-200

Technical parameters

"Forward-out" Type Metal Baler

Model: Y81Q-200

Power System (Motor, 2 sets)

Type: Y180M-4
 Rated Power: 18.5 kW (/set)
 Rated Speed: 1470 rpm
 Power Spec: 3PH, 50 / 60Hz

System Parameters

Lid Cyl. Force: 50 Ton
 Main Pressure Cyl. Force: 200 Ton
 Front Door Cyl. Force: 2×24 Ton
 Hydraulic System Pressure: 25 MPa
 Idle Cycle Time: Approx. 70 Sec

Hydraulic System (Pump, 2 sets)

Type: 80YCY14-1B
 Rated Displacement: 80 ml/r (/set)
 Max Operating Pressure: 31.5 MPa

Standard Configuration

A3 Steel Liners, Surface Heat Treatment.

Operation System (Optional)

Option 1: Manual Valve Operation
 Option 2: PLC Operation

Optional Configuration

Cutting Blades & Teeth (2 sides);
 Cooler / Heater;
 Diesel / Diesel Generator for Power.

General Description

Main Machine Size (L×W×H): 4200×1500×2200 mm
 Press Box Size (L×W×H): 1400×700×600 mm
 Bale Size (W×H): 700×280 mm
 Bale Weight (Steel): 70-100 kg
 Production Rate (Steel): 1.8-2.5 tons/hr
 Shipping Weight: Approx. 9 tons
 Loading (Standard Containers):

Hydraulic Oil Brand

Oil Tank Volume: 1400 ltr

ISO VG	China	U.S.		Britain	France
	GB11118.1	CALTEX CO.	MOBIL	SHELL	ELF CO.
HM 46	46 #	Rando HD46	D.T.E46	Tellus 46	Elfolna 46
HM 68	68 #	Rando HD68	D.T.E68	Tellus 68	Elfolna 68

Above information are indicative not engaging. Rights reserved for change if necessary.