

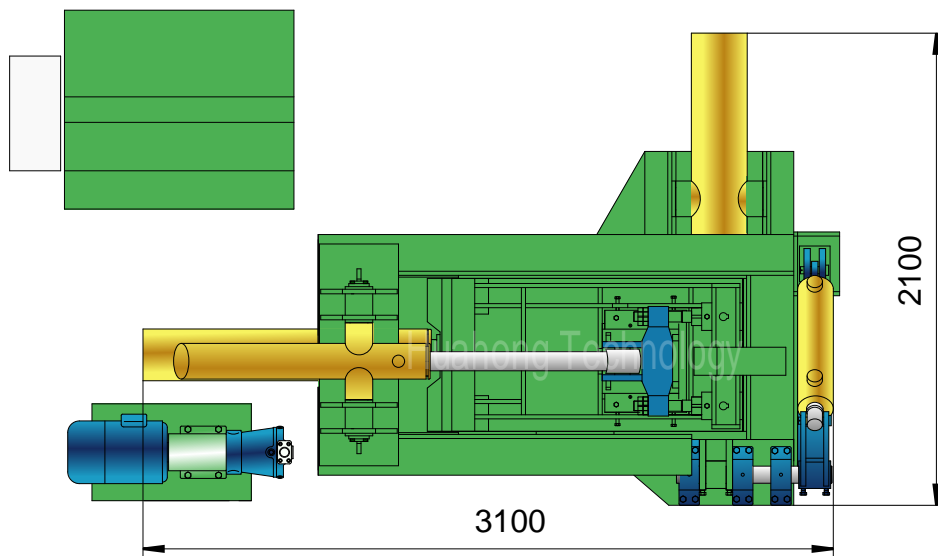

Y81F-100

Plan View

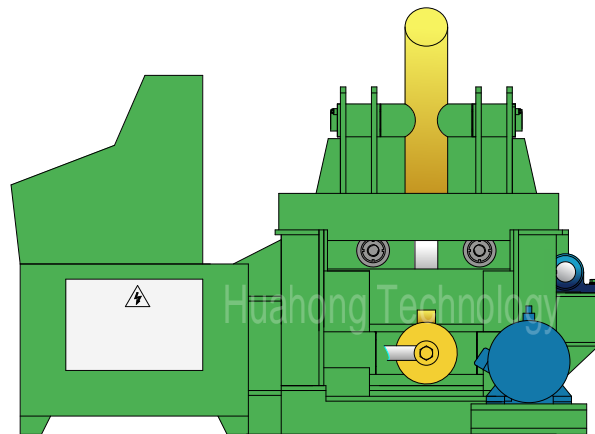

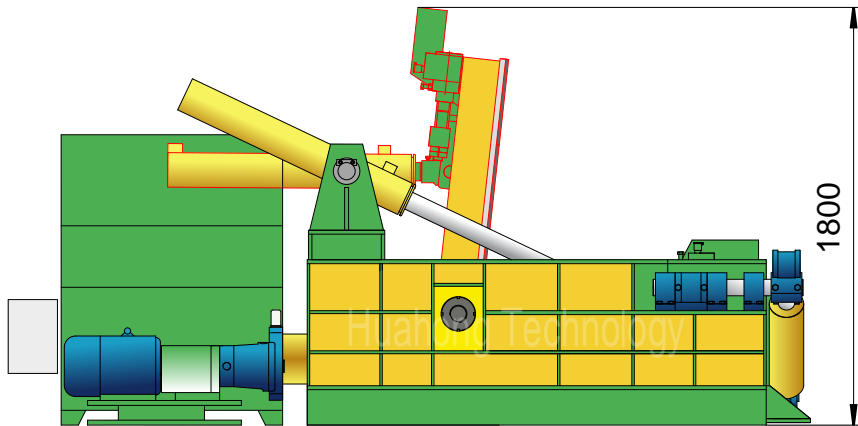

Y81F-100

Technical parameters

"Turn-out" Type Metal Baler

Model: Y81F-100

Power System (Motor)

Type: Y160M-4
 Rated Power: 11 kW
 Rated Speed: 1460 rpm
 Power Spec: 3PH, 50 / 60Hz

System Parameters

Lid Cyl. Force: 24 Ton
 Side Pressure Cyl. Force: 80 Ton
 Main Pressure Cyl. Force: 100 Ton
 Bale Discharge Cyl. Force: 8 Ton
 Hydraulic System Pressure: 25 MPa
 Idle Cycle Time: Approx. 100 Sec

Hydraulic System (Pump)

Type: 40YCY14-1B
 Rated Displacement: 40 ml/r
 Max Operating Pressure: 31.5 MPa

Operation System

Manual Valve Operation

Standard Configuration

A3 Steel Liners, Surface Heat Treatment.

Optional Configuration

Cutting Blades & Teeth (2 sides);
 Cooler / Heater;
 Diesel / Diesel Generator for Power.

General Description

Main Machine Size (L×W×H): 3100×2100×1800 mm
 Press Box Size (L×W×H): 1150×650×550 mm
 Bale Size (W×H): 200×200 / 230×230 / 250×250 mm
 Bale Weight (Steel): 20-45 kg
 Production Rate (Steel): 0.5-1.0 ton/hr
 Shipping Weight: Approx. 4.3 tons
 Loading (Standard Containers):

Hydraulic Oil Brand

Oil Tank Volume: 180 ltr

ISO VG	China	U.S.		Britain	France
	GB11118.1	CALTEX CO.	MOBIL	SHELL	ELF CO.
HM 46	46 #	Rando HD46	D.T.E46	Tellus 46	Elfolna 46
HM 68	68 #	Rando HD68	D.T.E68	Tellus 68	Elfolna 68

Above information are indicative not engaging. Rights reserved for change if necessary.