

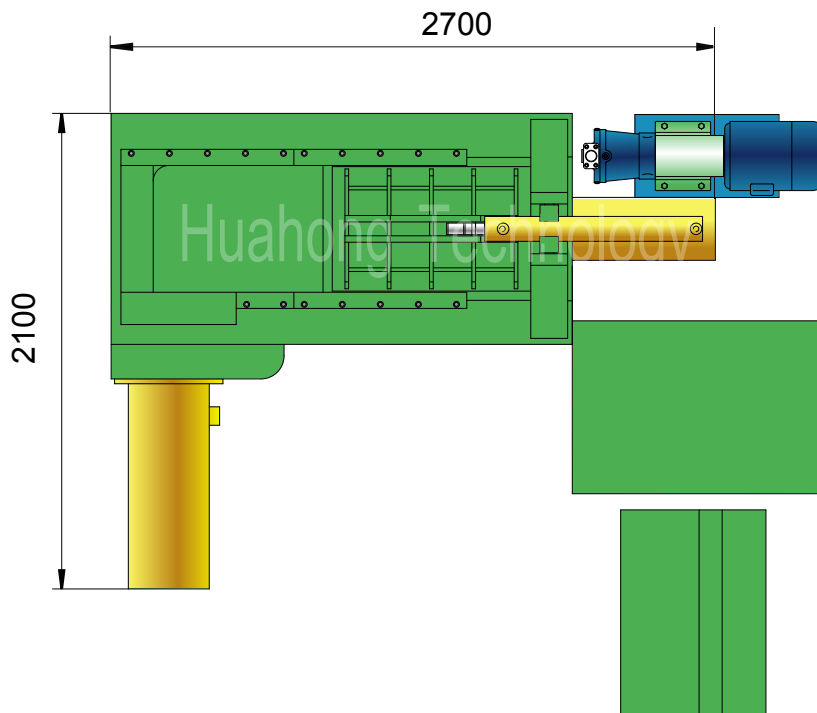

**Y81-150Y**

Plan View

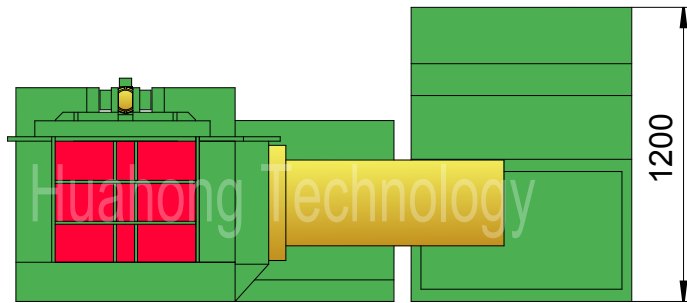

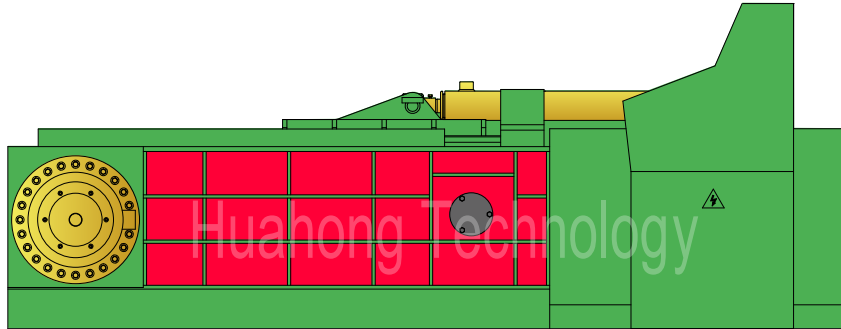

# Y81-150Y

## Technical parameters

### "Round-bale" Metal Baler

Model: Y81-150Y

### Power System (Motor)

Type: Y200L1-6  
 Rated Power: 18.5 kW  
 Rated Speed: 970 rpm  
 Power Spec: 3PH, 50 / 60Hz

### System Parameters

Lid Cyl. Force: 12.5 Ton  
 Side Pressure Cyl. Force: 100 Ton  
 Main Pressure Cyl. Force: 150 Ton  
 Hydraulic System Pressure: 25 MPa  
 Idle Cycle Time: Approx. 100 Sec

### Hydraulic System (Pump)

Type: 80YCY14-1B  
 Rated Displacement: 80 ml/r  
 Max Operating Pressure: 31.5 MPa

### Standard Configuration

A3 Steel Liners, Surface Heat Treatment.

### Operation System

PLC Operation

### Optional Configuration

Cooler / Heater;  
 Diesel / Diesel Generator for Power.

### General Description

Main Machine Size (L×W×H): 2700×2100×1200 mm  
 Press Box Size (L×W×H): 900×550×500 mm  
 Bale Size (Dia×H): φ135×500 mm  
 Bale Weight (Steel): Approx. 20 kg  
 Production Rate (Steel): 0.4-0.5 tons/hr  
 Shipping Weight: Approx. 4.4 tons  
 Loading (Standard Containers):

### Hydraulic Oil Brand

Oil Tank Volume: 600 ltr

ISO VG	China	U.S.		Britain	France
	GB11118.1	CALTEX CO.	MOBIL	SHELL	ELF CO.
HM 46	46 #	Rando HD46	D.T.E46	Tellus 46	Elfolna 46
HM 68	68 #	Rando HD68	D.T.E68	Tellus 68	Elfolna 68

Above information are indicative not engaging. Rights reserved for change if necessary.