

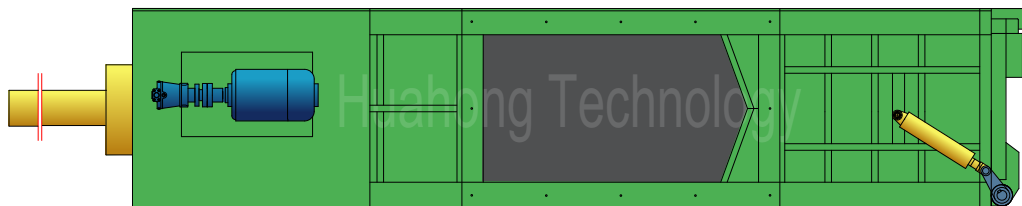

# HPM125A

## Plan View

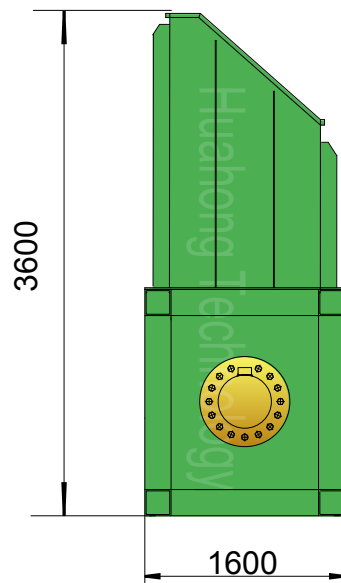

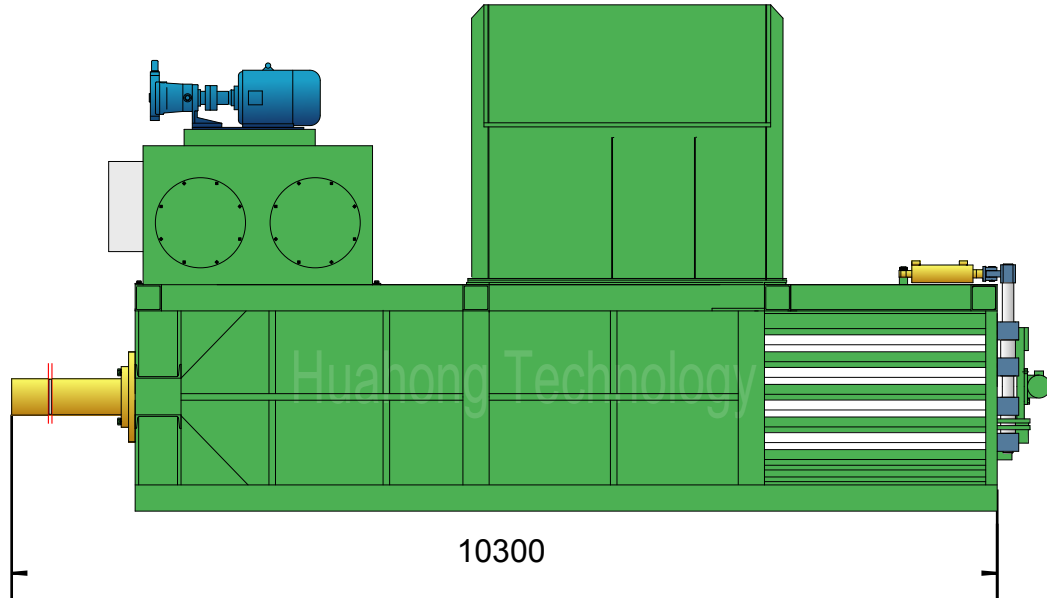

# HPM125A

## Technical parameters

### Horizontal Baler (Manual Belting)

Model: HPM125A

### Power System (Main Motor)

Type:	Y250M-6
Rated Power:	37 kW
Rated Speed:	980 rpm
Power Spec:	3PH, 50 / 60Hz

### System Parameters

Main Pressure Cyl. Force:	125 Ton
Locking Cyl. Force:	23.5 Ton
Open-door Cyl. Force:	12.5 Ton
Hydraulic System Pressure:	25 MPa

### Hydraulic System (Pump, 2 sets)

Pump #1:	250YCY14-1B
Rated Displacement:	250 ml/r
Max Operating Pressure:	31.5 MPa

### Standard Configuration

V-shaped Cutting Blades; Oil Cooler;  
Conveyor Width 1600mm, Powered by 7.5kW Motor;  
Discharging Roll Powered by 0.75kW Motor.

Pump #2:	25YCY14-1B
Rated Displacement:	25 ml/r
Max Operating Pressure:	31.5 MPa

### Optional Configuration

NOK (JAPAN) Seal Packings for Cylinders;  
Oil Heater; Magnetic Oil Filter;  
Diesel / Diesel Generator for Power.

### Operation System

PLC Operation

### General Description

Main Machine Size (L×W×H):	10300×1600×3600 mm
Feeding Opening (L×W):	2200×1100 mm
Bale Size (W×H):	1100×900 mm
Bale Weight (Cardboard):	630-900 kg
Production Rate (Cardboard):	3.8-5.4 tons/hr
Strapping:	Tempered Iron Wire, φ2.8/3.2mm, 4 Lines, Manual Strapping.
Shipping Weight:	Approx. 14.3 + 7 tons
Loading (Standard Containers):	2×40'GP

### Hydraulic Oil Brand

Oil Tank Volume: 2000 ltr

ISO VG	China	U.S.		Britain	France
	GB11118.1	CALTEX CO.	MOBIL	SHELL	ELF CO.
HM 46	46 #	Rando HD46	D.T.E46	Tellus 46	Elfolna 46
HM 68	68 #	Rando HD68	D.T.E68	Tellus 68	Elfolna 68

Above information are indicative not engaging. Rights reserved for change if necessary.